

84/85/86 Series

Cylinder Actuator

Instruction Manual (Rev.D)

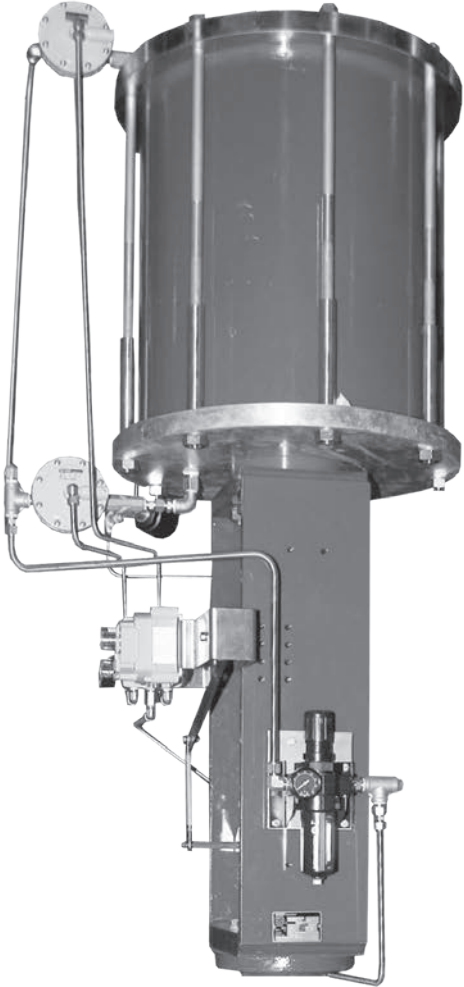

THESE INSTRUCTIONS PROVIDE THE CUSTOMER/OPERATOR WITH IMPORTANT PROJECT-SPECIFIC REFERENCE INFORMATION IN ADDITION TO THE CUSTOMER/OPERATOR'S NORMAL OPERATION AND MAINTENANCE PROCEDURES. SINCE OPERATION AND MAINTENANCE PHILOSOPHIES VARY, BAKER HUGHES COMPANY (AND ITS SUBSIDIARIES AND AFFILIATES) DOES NOT ATTEMPT TO DICTATE SPECIFIC PROCEDURES, BUT TO PROVIDE BASIC LIMITATIONS AND REQUIREMENTS CREATED BY THE TYPE OF EQUIPMENT PROVIDED.

THESE INSTRUCTIONS ASSUME THAT OPERATORS ALREADY HAVE A GENERAL UNDERSTANDING OF THE REQUIREMENTS FOR SAFE OPERATION OF MECHANICAL AND ELECTRICAL EQUIPMENT IN POTENTIALLY HAZARDOUS ENVIRONMENTS. THEREFORE, THESE INSTRUCTIONS SHOULD BE INTERPRETED AND APPLIED IN CONJUNCTION WITH THE SAFETY RULES AND REGULATIONS APPLICABLE AT THE SITE AND THE PARTICULAR REQUIREMENTS FOR OPERATION OF OTHER EQUIPMENT AT THE SITE.

THESE INSTRUCTIONS DO NOT PURPORT TO COVER ALL DETAILS OR VARIATIONS IN EQUIPMENT NOR TO PROVIDE FOR EVERY POSSIBLE CONTINGENCY TO BE MET IN CONNECTION WITH INSTALLATION, OPERATION OR MAINTENANCE. SHOULD FURTHER INFORMATION BE DESIRED OR SHOULD PARTICULAR PROBLEMS ARISE WHICH ARE NOT COVERED SUFFICIENTLY FOR THE CUSTOMER/OPERATOR'S PURPOSES THE MATTER SHOULD BE REFERRED TO BAKER HUGHES.

THE RIGHTS, OBLIGATIONS AND LIABILITIES OF BAKER HUGHES AND THE CUSTOMER/OPERATOR ARE STRICTLY LIMITED TO THOSE EXPRESSLY PROVIDED IN THE CONTRACT RELATING TO THE SUPPLY OF THE EQUIPMENT. NO ADDITIONAL REPRESENTATIONS OR WARRANTIES BY BAKER HUGHES REGARDING THE EQUIPMENT OR ITS USE ARE GIVEN OR IMPLIED BY THE ISSUE OF THESE INSTRUCTIONS.

THESE INSTRUCTIONS ARE FURNISHED TO THE CUSTOMER/OPERATOR SOLELY TO ASSIST IN THE INSTALLATION, TESTING, OPERATION, AND/OR MAINTENANCE OF THE EQUIPMENT DESCRIBED. THIS DOCUMENT SHALL NOT BE REPRODUCED IN WHOLE OR IN PART WITHOUT THE WRITTEN APPROVAL OF BAKER HUGHES.

Table Of Contents

- Safety Information 1**
 - About this Manual 1
 - Warranty..... 1
- 1. Introduction..... 2**
- 2. General 2**
 - Numbering System..... 2
- 3. Actuator Removal 3**
 - 3.1 Air to Extend (Model 84)..... 3
 - 3.2 Air to Retract (Model 85) 3
 - 3.3 Double Acting/No Springs (Model 86)..... 3
 - 3.4 On actuators with hydraulic manual override systems 3
- 4. Actuator Disassembly 4**
- 5. Equipment 4**
- 6. Actuator Reassembly Procedures 4**
 - 6.1 General 4
 - 6.2 Procedure for Air to Extend Models 5
 - 6.3 Procedure for Air to Retract Models 5
 - 6.4 Closing the Cylinder 5
 - 6.5 Procedure for Hydraulic Manual Override..... 6
- 7. Testing 6**
 - 7.1 Case Pressure Integrity..... 6
 - 7.2 Acceptable Criteria 6
- 8. Hydraulic Manual Override Instructions 6**
- 9. Filling the Reservoir Single Acting and Double Acting Units 7**
- 10. Parts Reference 10**
 - Actuator and Yoke 11
 - Recommended Spare Parts..... 11

Safety Information

Important - Please read before installation

These instructions contain **DANGER**, **WARNING**, and **CAUTION** labels, where necessary, to alert you to safety related or other important information. Read the instructions carefully before installing and maintaining your control valve. **DANGER** and **WARNING** hazards are related to personal injury. **CAUTION** hazards involve equipment or property damage. Operation of damaged **equipment can, under certain operational conditions, result in degraded process system performance that can lead to injury or death. Total compliance with all DANGER, WARNING, and CAUTION notices is required for safe operation.**



This is the safety alert symbol. It alerts you to potential personal injury hazards. Obey all safety messages that follow this symbol to avoid possible injury or death.



Indicates a potentially hazardous situation which, if not avoided, could result in death or serious injury.



Indicates a potentially hazardous situation which, if not avoided, could result in serious injury.



Indicates a potentially hazardous situation which, if not avoided, could result in minor or moderate injury.



When used without the safety alert symbol, indicates a potentially hazardous situation which, if not avoided, could result in property damage.

Note: Indicates important facts and conditions.

About this Manual

- The information in this manual is subject to change without prior notice.
- The information contained in this manual, in whole or part, shall not be transcribed or copied without Baker Hughes's written permission.
- Please report any errors or questions about the information in this manual to your local supplier.
- These instructions are written specifically for the Masoneilan™ 84, 85, 86 Series Cylinder Actuators, and do not apply for other actuators outside of this product line.

Useful Life Period

The current estimated useful life period for the 84, 85, 86 Series Cylinder Actuators is 25+ years. To maximize the useful life of the product, it is essential to conduct annual inspections, routine maintenance and ensure proper installation to avoid any unintended stresses on the product. The specific operating conditions will also impact the useful life of the product. Consult the factory for guidance on specific applications if required prior to installation.

Warranty

Items sold by Baker Hughes are warranted to be free from defects in materials and workmanship for a period of one year from the date of shipment provided said items are used according to Baker Hughes recommended usages. Baker Hughes reserves the right to discontinue manufacture of any product or change product materials, design or specifications without notice.

Note: Prior to installation:

- The control valve and actuator must be installed, put into service and maintained by qualified and competent professionals who have undergone suitable training.
- All surrounding pipe lines must be thoroughly flushed to ensure all entrained debris has been removed from the system.
- All air supply to the actuator must be turned off.
- Under certain operating conditions, the use of damaged equipment could cause a degradation of the performance of the system which may lead to personal injury or death.
- Changes to specifications, structure, and components used may not lead to the revision of this manual unless such changes affect the function and performance of the product.

1. Introduction

The following instructions are designed to assist maintenance personnel in performing most of the maintenance required on 84, 85, 86 Series Cylinder Actuators. Baker Hughes has highly skilled service engineers available for start-up, maintenance and repair of our actuators and component parts. In addition, a regularly scheduled training program is conducted at the Training Center to train customer service and instrumentation personnel in the operation, maintenance and application of our control valves and instruments. Arrangements for these services can be made through your Baker Hughes Representative or Sales Office. When performing maintenance, use only Masoneilan replacement parts. Parts are obtainable through your local Baker Hughes Representative or Sales Office. When ordering parts, always include Model and Serial Number of the unit being repaired.

2. General

The following is a step by step procedure for the assembly and disassembly of the 84, 85, 86 Series Cylinder Actuators. Hydraulic manual override instructions are included on page 7.

The intent of this procedure is to provide all the specialized data necessary to properly assemble, disassemble and test these actuators.

These instructions are written for use by a qualified person. Therefore, proper use of lifting and fixturing devices are assumed to be used. Various parts of this actuator are large, cumbersome and potentially dangerous if not handled properly. Proper equipment and training of personnel is the responsibility of the user.

Throughout this text item numbers relating to the appropriate parts of the assembly are noted in () parenthesis after each part reference to facilitate layout examination and assembly. At this point, it is wise to visually examine each part for defects.

Model 84 is air to extend (direct)

Model 85 is air to retract (reverse)

Model 86 is double acting cylinder (no springs)

The cylinder should be disassembled once every 5 years at a minimum, to relubricate the cylinder and replace all soft goods. For equipment with high cycle rates, the cylinder may require more frequent disassembly. Prior to disassembly, check the cylinder for leakage across the piston by pressurizing one side of the cylinder. Cylinder, rod and bushing should be inspected for wear or damage and replaced as necessary.

Numbering System

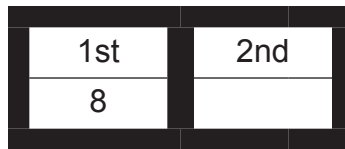

Actuator Type		
84	Air to Extend	(Direct)
85	Air to Retract	(Reverse)
86	Double Acting Cylinder	(No Springs)

3. Actuator Removal

Before removal from the valve and disassembly, the unit should be isolated, with the air supply lines to the cylinder removed and the system pressure to the valve cut off. Prior to disassembly, pneumatic volume tanks should be emptied, so that no trapped air remains in the cylinder. Also all of the electrical connections to the actuator are to be disconnected.

Maintenance of the actuator normally requires removal of the actuator from the valve body. The steps in removal of the actuator are different depending on whether the actuator is air to extend (Model 84) or air to retract (Model 85) or double acting (no springs - Model 86).

Note: Instructions are general in nature. Check valve instructions for additional instructions.

Note: Actuator action may be checked by referring to the valve identification tag.

3.1 Air to Extend (Model 84)

- A. Loosen locknuts (28 and 32)
- B. Apply required air pressure to top cap (13) to put valve plug on seat. Check anti-rotation plate (9) against travel indicator (10) to ensure that plug is on seat.

CAUTION

Do not exceed supply pressure indicated on the working pressure tag.

- C. Remove flat head cap screws (8) and anti-rotation plate (9).
- D. Remove cap screws (29) from top and bottom stem connectors (30 and 31).
- E. Shut off air supply to top cap (13).
- F. Bleed off all air pressure in cylinder.
- G. Disconnect air piping from top cap (13).
- H. Remove bottom stem connector (31) and nut (32) from valve plug stem.
- I. Loosen and remove drive nut, which holds the yoke (7) to valve body or bonnet.
- J. Remove actuator.
- K. Remove top stem connector (30), nuts (28) and stem extension (27) from piston stem (5).
- L. On units without hydraulic manual override, loosen and remove cap screws (3) which hold stem cap (39) to top cap (13). Then, remove stem cap (39) up off the upper stem (38).

3.2 Air to Retract (Model 85)

Since removal of the valve plug stem from the actuator bottom stem connector (31) requires that the valve plug be off the seat, air supply has to be introduced to the bottom cap (19) to assure that the valve is in the partially opened position.

Proceed as follows:

- A. Apply required air pressure to the bottom cap (19) to open valve to mid stroke.

CAUTION

Do not exceed supply pressure indicated on the working pressure tag.

- B. Check anti-rotation plate (9) against travel indicator (10) to ensure that valve plug is at mid stroke.
- C. Loosen locknuts (28 and 32).
- D. Shut off air supply to bottom cap (19).
- E. Bleed off all air pressure in cylinder.
- F. Remove flat head cap screws (8) and anti-rotation plate (9).
- G. Remove cap screws (29) from top and bottom stem connectors (30 and 31).
- H. Apply required air pressure to the bottom cap (19) to retract piston stem (5) to mid stroke.
- I. Check top stem connector (30) against travel indicator (10) to ensure that piston stem (5) is at mid stroke.
- J. Remove bottom stem connector (31) and nut (32) from valve plug stem.
- K. Loosen and remove drive nut, which holds yoke (7) to valve body or bonnet.
- L. Shut off air supply to cylinder.
- M. Bleed off all air pressure in cylinder.
- N. Disconnect air piping from bottom cap (19).
- O. Remove actuator.
- P. Now remove top stem connector (30), nut (28) and stem extension (27) from piston stem (5).
- Q. On units without hydraulic manual override. Loosen and remove cap screws (3) which hold stem cap (39) to top cap (13). Then remove stem cap (39) up off the upper stem (38).

3.3 Double Acting/No Springs (Model 86)

- A. Shut off and disconnect air supply to top cap (13). This will help bleed off air above the piston (1).
- B. Apply required air pressure to bottom cap (19) to open the valve to mid stroke as is indicated by the anti-rotation plate (9) against travel indicator (10).

CAUTION

Do not exceed supply pressure indicated on the working pressure tag.

- C. Follow procedures as laid out in 3.2 A through 3.2 Q.

3.4 On actuators with hydraulic manual override systems,

the hydraulic cylinder and handjack assembly (33) should be removed from the top cap (13) by the following procedures.

- A. Remove nuts (57) from hydraulic cylinder tie-rods.
- B. Remove stem cap (39).
- C. With a wrench placed on the flats of the hydraulic cylinder piston rod, loosen this rod 1/2 turn to initially loosen it from handjack extension (36).
- D. Remove cap screws (34).
- E. Rotate the hydraulic cylinder piston rod counter-clockwise to remove it from handjack extension (36).

4. Actuator Disassembly

CAUTION

The cylinder actuator is a spring loaded device and the disassembly instructions should be adhered to as given below or damage to the unit or bodily injury can occur.

- 4.1 Carefully and evenly in a crisscross pattern loosen cap screws (17), one turn at a time, from extended nuts (18) on top of the actuator. Remove cap screws (17), flat washers (12) and top cap (13) from the cylinder (6). Remove extended nuts (18) and flat washers (20) from bottom cap (19). Refer to 4.7 for soft goods removal.

4.2 Air to Retract

Remove spring (14) from cylinder. Then carefully slide upper stem (38) [handjack extension (36) on hydraulic manual override units] along with piston stem (5) and piston (1) out of cylinder (6).

Air to Extend

Carefully slide upper stem (38) [handjack extension (36) on hydraulic manual override units], piston stem (5) and piston (1) out of cylinder (6). Then remove springs (14).

- 4.3 Remove cylinder (6) from bottom cap (19).
- 4.4 Remove cap screws (21) on inside top of yoke (7). Lift bottom cap (19) assembly from top of yoke (7).
- 4.5 Remove retaining ring (23) which holds bushing (24) into the bottom cap (19). Remove bushing (24) from bottom cap (19).
- 4.6 Remove retaining ring (23) which holds bushing (24) into the top cap (13). Remove bushing (24) from top cap (13).
- 4.7 Soft Goods (guide rings, o-rings and stem wipers) Removal:
 - A. Remove and discard o-rings (2, 22, 25 and 35).
 - B. Remove and save guide rings (59) piston (1) for reuse, if they are not damaged.
 - C. Remove and discard stem wipers (26) from the bushings (24).
 - D. Examine the guiding and sealing surfaces on the top and bottom caps (13 and 19), piston (1) cylinder (6) and bushings (24) for excessive wear and damage.

- 4.8 Disassembly of the piston (1) and piston stem (5) is optional and required only if leakage was occurring across piston (1) in the cylinder.

In that case, disassemble the piston (1) and piston stem (5) assembly by first removing upper stem (38) [handjack extension (36) on hydraulic manual override units] from piston (5). Then remove travel stop (15) and piston rod spacer (16) from piston stem (5). Lastly, remove piston stem (5) out of piston (1).

5. Equipment

In addition to the parts listed on the part list, the following items are necessary for proper assembly.

- A. Appropriate wrenches for the following head sizes and types:
 - 17/16 Hex
 - 11/4 Hex
 - 11/2 Hex
 - 9/16 Hex Tube Fitting
 - 11/16 Hex Tube Fitting
 - 7/8 Hex Tube Fitting
 - 1/2 Allen Wrench
- B. Torque wrench capable of 115 ft/lbs minimum or appropriate bolt tensioners.
- C. "Never Seez" (anti-seize compound). Never Seez[®] Corp. Catalog No. NSBT 16 (or equal).
- D. Loctite[®] Plastic Gasket Seal No. 54941.
- E. Dow Corning[™] "Valve Lubricant and Sealant Compound 111" (No substitute).
- F. Teflon[®] thread sealing tape.
- G. Loctite[®] Thread Locker No. 242.

6. Actuator Reassembly Procedures

6.1 General

- A. Secure the yoke (7) in an upright position in an appropriate fixture.
- B. Apply a generous amount of "Compound 111" to the bushings (24) inside and outside diameters. Being sure to coat the o-ring grooves.
- C. Assemble stem wipers (26) to bushings (24).
- D. Assemble o-rings (22 and 25) to bushings (24).
- E. Slide bushing (24) into bottom cap (19) and secure it with retaining ring (23). Slide the second bushing (24) into top cap (13) and secure it with retaining ring (23). On H.M.O. units, second guide bushing installation into top cap is not required.
- F. Apply "Never Seez" to cap screw (21) threads, also under and around screw head.
- G. Thread cap screws (21) through yoke (7) and into bottom cap (19). Tighten to a torque of 100 ft/lbs.

- H. Apply “Loctite Sealant No. 54941” to the surfaces of the internal threads on piston (1) and external threads on piston stem (5). The threaded surfaces are where the two parts come together.
- I. Apply Loctite No. 242 to the center hole threads of the travel stop (15).
- J. Assemble the piston (1), spacer (16), travel stop (15) and the stem (5). Tighten both threaded connections to a minimum torque of 450 ft/lbs.

Note: In lieu of equipment that will produce the required torque. An approximation may be obtained by applying a 150 lb force (approximately the weight of an average man) to a wrench handle 3 feet away from stem.

- K. Remove the excess thread sealant and lubricant from the bottom cap (19) and stem assembly before proceeding.

Note: The highest degree of cleanliness must be maintained during assembly. Instruments used to meter air to and from the cylinder are susceptible to clogging and subsequent malfunction from even minute particles of foreign matter.

- L. Prepare the cylinder (6) by applying a generous amount of “Compound 111” to the wear area of its inside diameter.
- M. Prepare the required number of cap screws (17) and extended nuts (18), by coating the threads and bearing surfaces with “Never Seez” anti-seize compound and assemble flat washers (12) and (20).
- N. Apply a generous amount of “Compound 111” to the bottom cap (19) O-ring groove and to the O-ring (2).
- O. Install the O-ring into the bottom cap (19).

6.2 Procedure for Air to Extend Models

- A. The spring or springs (14) must now be placed in their appropriate grooves in the bottom cap (19).
- B. Place the prepared cylinder (6) with its greased portion up onto the bottom cap (19). The cylinder should slide over the O-ring with a minimum amount of force applied around the top of the cylinder.
- C. Apply a generous amount of “Compound 111” to the outside diameter of the piston (1) and being sure to coat the O-ring and guide ring grooves.
- D. Apply a coating of “Compound 111” to the O-ring (2) and install it into the O-ring groove in the piston (1).
- E. Apply a coating of “Compound 111” to the guide ring (59).
- F. Using the lifting holes provided, hoist the stem and piston assembly over the yoke and bottom cap assembly.

Note: When assembling any air to extend spring return cylinder with hydraulic override, it is recommended to use the assembly tool shown in Appendix B. This tool must be used on air to extend spring return cylinders to avoid damage to the bushing during Step 6.2 G.

The assembly tool is used by threading it hand tight onto the lower end of the piston stem (5). It provides an extension of the actuator stem which is used for guiding the stem through the bushing as required in Step 6.2 G.

- G. With the assembly tool attached to the lower end of the piston stem (5), carefully lower the stem and piston assembly until it comes to rest on the springs and piston stem (5) fits into and through the lower guide bushing (24).

6.3 Procedure for Air to Retract Models

- A. Prepare for installation of the cylinder by applying a generous amount of “Compound 111” to the outside diameter of the piston (1), being sure to coat the O-ring and guide ring grooves.
- B. Apply a coating of “Compound 111” to the O-ring (2) and install it into the O-ring groove in the piston (1). Also apply a coating of “Compound 111” to the guide ring (59).
- C. Lower the piston and stem assembly onto the bottom cap (19) and through the lower guide bushing (24).
- D. Lower the cylinder (6) greased portion down over the piston (1) until it approaches the guide ring groove on piston (1). At this point, install guide ring (59) onto piston (1).

Note: The guide ring may be one piece or two piece construction.

- E. Continue sliding the cylinder (6) down over the guide ring (59) and O-ring (2) in piston (1) until the bottom cap O-ring (2) is properly engaged.

Note: The cylinder must be fairly well aligned with the piston during installation. With such alignment, hand force applied to the top edges of the cylinder should be sufficient to complete the installation. Should considerable more force be required inspection of the alignment of the bore and piston and proper location of the O-ring (2) and guide ring (59) is advised.

- F. Lower the springs (14) into place, being sure that they are properly seated in their respective grooves on the piston (1).
- G. Prepare the top cap (13) for assembly by applying “Compound 111” to the O-ring groove.
- H. Coat the O-ring (2) with “Compound 111” and place it in the top cap (13) O-ring groove.
- I. Lift the top cap (13) into position.

Note: For air to retract be sure the springs are in their proper grooves on the piston (1).

- J. Place the previously prepared cap screws (17) with washers (12) through the holes in the top cap (13).
- K. Fit the extended nuts (18) with washers (20) through the holes in the bottom cap (19) and thread them onto the cap screws (17) finger tight.

6.4 Closing the Cylinder

Note: The following operation is the most difficult part of the assembly. If the procedure is not followed as closely as possible it is likely that damage to the cylinder or bushing will occur.

A. Air to Extend

- 1. Place the prepared guide ring (59) into its groove in the piston (1).

Note: The guide ring may be one piece or two piece construction.

- 2. As the top cap (13) is pulled down towards the cylinder by evenly hand tightening cap screws (17), the guide ring groove on the piston with the ring (59) in it, will approach the top of the cylinder (6).
- 3. Tighten cap screws (17) evenly so that the piston (1) with its O-ring (2) and guide ring (59) in place will engage in the cylinder (6) I.D. bore.

Note: A feel for this operation must be developed by the assembly technicians. It is suggested that initial tightening be done at approximately one turn at a time. Changes in rates may be made as the assembler becomes more familiar with the procedure. Multiple automatic wrenches with a synchronized turning rate is a possible alternate method. Baker Hughes offers hydraulic handjack tools for preloading the actuator.

4. As evenly as possible, continue tightening the cap screws (17) until the top cap O-ring (2) is fully engaged in the cylinder (6) and contact between the cylinder (6) and top cap (13) is made.

B. Air to Retract

1. Tighten the cap screws (17) as evenly as possible until the top cap O-ring (2) is fully engaged and contact between the edge of the cylinder (6) and top cap (13) is made.

CAUTION

Do not continue to tighten cap screws (17) after contact is made between top cap (13) and cylinder (6). Over tightening may result in damage to the cylinder (6). See Step C.

2. Tighten the cap screws (17) with 100 ft/lbs of torque.
3. Remove assembly tool from bottom of piston stem (5).
4. Apply Loctite No. 242 to stem extension (27) threads and install this part into piston stem (5).
5. Apply Loctite No. 242 to upper stem (38) threads, and then install the upper stem (38) into the top of piston stem (5) utilizing the flats on the upper stem (38) and piston stem (5), torque these two parts into place with 450 ft/lbs of torque.
6. Install stem cap (39) to top cap (13) with four cap screws (3).

6.5 Procedure for Hydraulic Manual Override

- A. Apply Loctite No. 242 to hydraulic cylinder rod internal threads. Then thread handjack extension (36) into the hydraulic cylinder rod until it is fully engaged. Utilizing the flats on the cylinder rod and extension (36), torque these two pieces into place with 450 ft/lbs of torque.
- B. Install O-ring (35) into the recess in the top cap (13).
- C. Lower the hydraulic cylinder (33) onto the top cap (13) by positioning the cylinder rod/handjack extension (36) through the top cap (13) bore.

Note: Before lowering hydraulic cylinder (33) onto top cap (13), apply Loctite No. 242 to the internal threads in top of the piston stem (5) where the handjack extension (36) screws in.

- D. While holding the piston stem (5) in place by using the flats on its lower end, rotate the hydraulic cylinder piston rod clockwise to thread handjack extension (36) into piston stem (5) until the mounting flange of the hydraulic cylinder is flush with the top cap (13).
- E. Prepare the cap screws (34) by applying “Never Seez” to the threads and bearing surfaces.

- F. Thread cap screws (34) finger tight.
- G. Using the flats on the upper end of the hydraulic cylinder rod and lower end of piston stem (5), torque the two parts into place with 450 ft/lbs of torque.
- H. Tighten the cap screws (34) to 115 ft/lbs of torque.
- I. Install stem cap (39) onto the top of the hydraulic cylinder (33).
- J. Assemble nuts (57) to top of hydraulic cylinder tie-rods and tighten to 25 ft/lbs.

7. Testing

7.1 Case Pressure Integrity

- A. Charge one side of the case with 70 psi of air and lock it in so that the pressure can be monitored.
- B. Inspect audible and visual signs of leakage.
- C. Check the suspected areas with suitable leak detection solution.
- D. After five minutes of pressure, observe the case pressure.
- E. Repeat Steps A thru D on opposite end of actuator.

7.2 Acceptable Criteria

Any observed loss in pressure is cause for rejection.

- A. Operate the actuator through a minimum of five full travel cycles using 1/4" O.D. tubing direct input and a Cv = 0.3 exhaust valve (Nupro Model JN straight body is acceptable). Inspect for the following: (1) Smoothness of operation (2) Length of travel and (3) Travel time.
- B. To disassemble actuator or manual hydraulic override, refer to disassembly instructions on page 4.
- C. All soft goods and bushing (24) should be inspected and replaced once every 5 years in the actuator, and inspected once every 10 years in the hydraulic cylinder and replaced if necessary.
- D. Hook up stem block (30, 31) and related hardware (27, 28, 29, & 32).

8. Hydraulic Manual Override Instructions

The hydraulic handjack is a secondary control system to provide the means to operate the valve when the primary pneumatic system fails. The system in one configuration is a single acting cylinder which acts against spring load. In the second configuration, the cylinder is connected in a double acting mode. The system requires no adjustments, and only minimal servicing (filling the reservoir) is required.

Note: Handjack assembly is shipped with the reservoir properly filled and with a pipe plug in the reservoir breather port. Remove pipe plug and replace with breather plug prior to operation. Orient valve with breather plug to top of reservoir (refer to sketches on page 9).

9. Filling the Reservoir Single Acting and Double Acting Units

- A. Assemble the hydraulic pump (33-2) to hydraulic cylinder (33-1) with the socket head cap screws (33-8).

Note: Make sure that the orientation of the hydraulic fluid fill hole on the pump (33-2) is at the top.

- B. Remove pipe plug from hydraulic fluid fill hole on the pump (33-2).
- C. Fill pump reservoir.
- D. With the actuator in its normal position (stem extended for double acting), fill the pump reservoir approximately 1/2 full with Mobil DTE 24 hydraulic fluid.
- E. Close the pump bypass and hand operate the actuator to its full travel position, adding fluid as necessary to maintain the 1/2 full level in the reservoir. This operation will assure that the hydraulic cylinder is filled with fluid.

CAUTION

Do not over fill reservoir.

- F. Install breather plug into the hydraulic fluid fill hole after the hydraulic fluid filling procedure.
- G. Assemble stem cap (39) to top of hydraulic cylinder, using 4 nuts (57) and tighten.

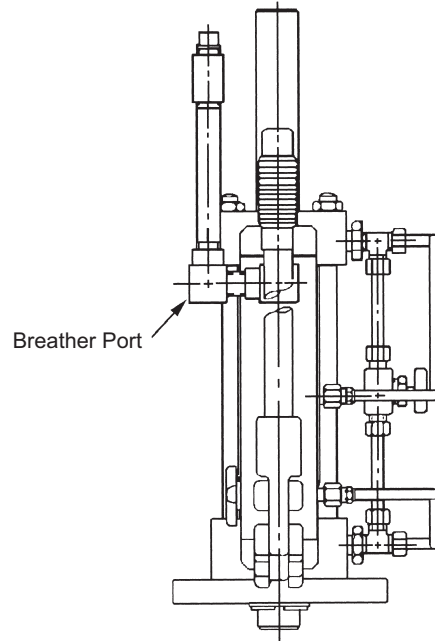

Valve Installation Vertical Preferred

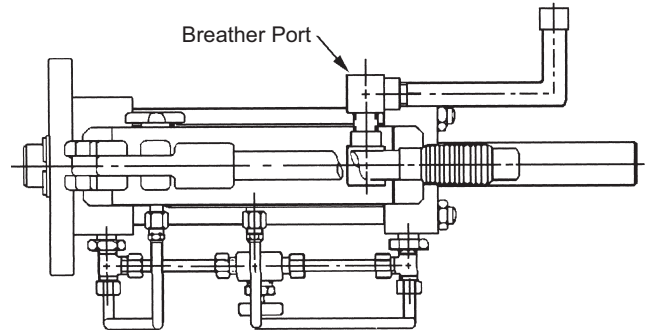

Valve Installation Horizontal

314 Sq. In. Piston Actuator without Handjack

10. Parts Reference

Ref No.	Description	Ref No.	Description	Ref No.	Description
1	Piston	21	Cap Screw, Hex Head	41	Pump Installation Tag
2 ¹	O-ring, Piston & Caps	22 ¹	O-ring, Bushing O.D.	42	Piston Stem
3 ¹	Cap Screw, Hex Head	23	Retaining Ring	43	Adapter Plate
5	Piston Stem	24 ¹	Bushing	44	Cap Screw, Socket Head
6	Cylinder	25 ¹	O-ring, Bushing I.D.	45	Stem Extension
7	Cast Yoke	26 ¹	Stem Wiper	46	Yoke
	Yoke S/A	27	Stem Extension	47	Stud
8	Cap Screw, Flat Head	28	Nut	48	Nut
9	Anti-Rotation Plate	29	Cap Screw, Socket Head	49	Cap Screw, Hex Head
10	Travel Indicator Plate	30	Stem Connector, Top	50	Lockwasher
11	Screw, Pan Head	31	Stem Connector, Bottom	51	Anti-rotation Arm
12	Flat Washer	32	Nut	52	Stem Block
13	Top Cap	33	Handjack Assembly	53	Stud
14	Spring	34	Cap Screw, Hex Head	54	Nut
15	Travel Stop	35 ¹	O-ring, Hydraulic Cylinder	55	Lockwasher
16	Spacer, Piston Rod	36	Handjack Extension	56	Pump Adapter (not shown)
17	Cap Screw	37	Filter Vent	57	Nut
18	Extended Nut	38	Upper Stem	58	Caution Plate
19	Bottom Cap	39	Stem Cap	59 ¹	Guide Ring
20	Flat Washer	40	Pipe Plug	60	Tag (not shown)
				62	Drive Nut (not shown)

1. Recommended Spare Parts

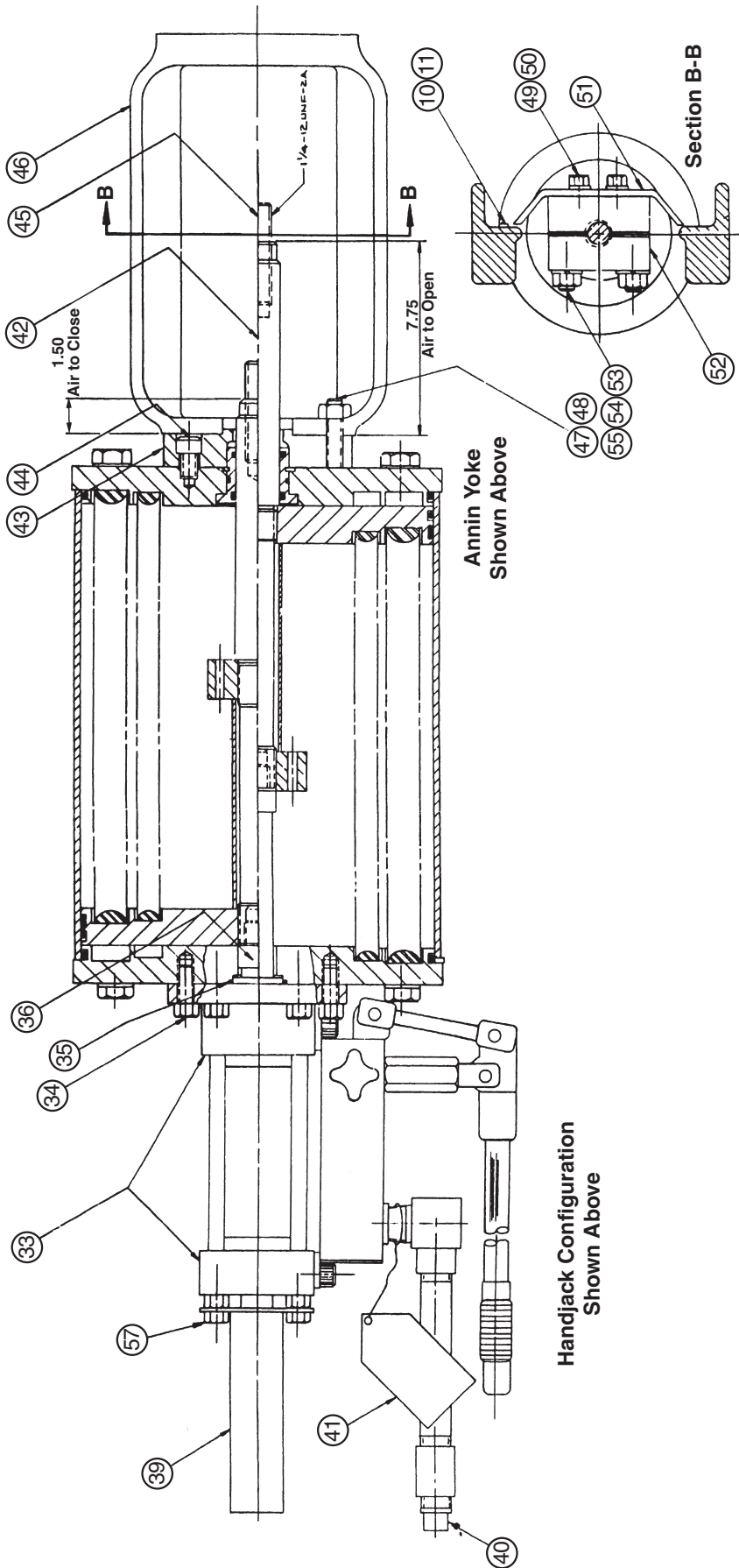

154 Sq. In. Piston Actuator with Handjack

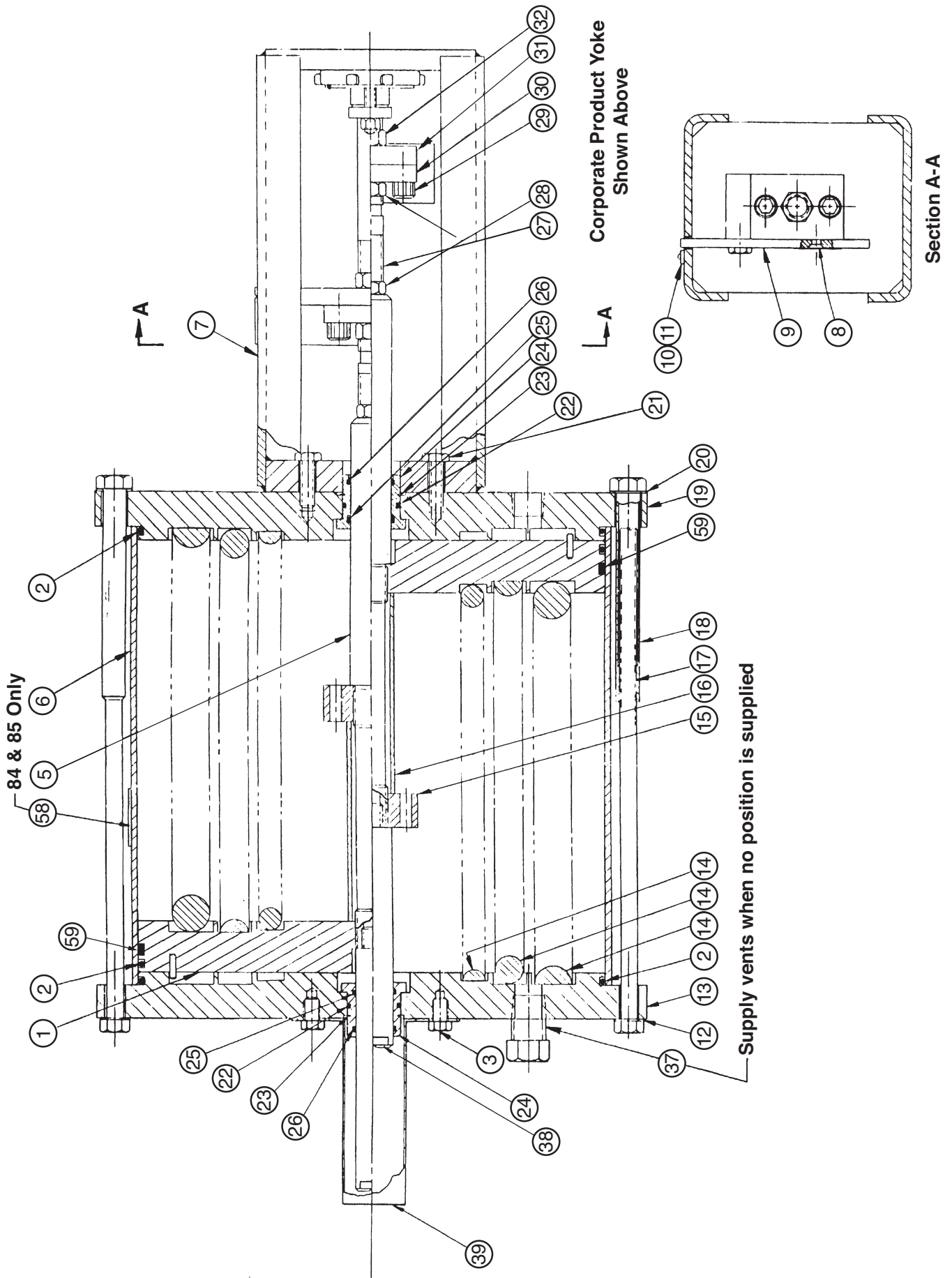

314 Sq. In. Piston Actuator without Handjack

Dimensions (in.)

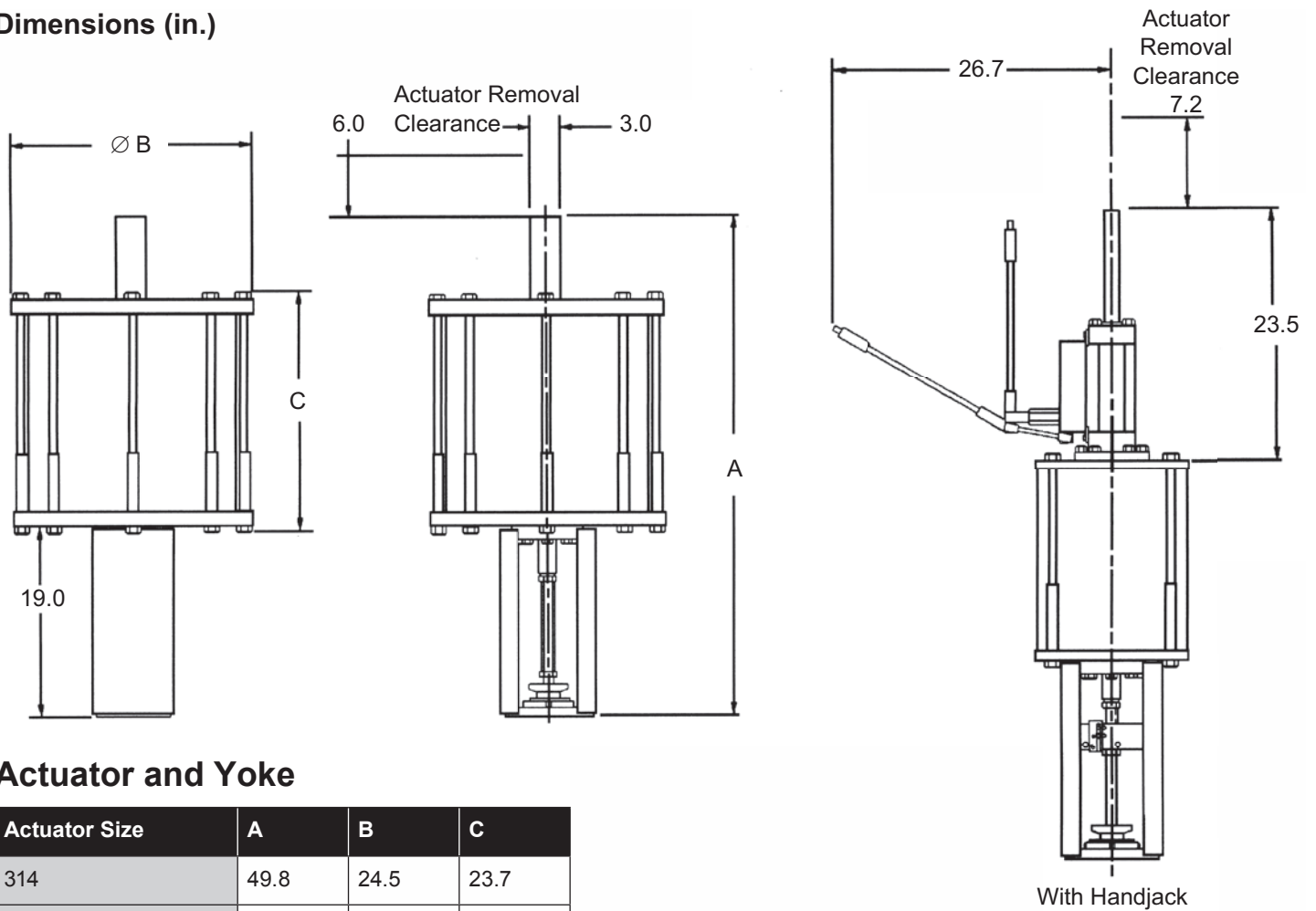

Actuator and Yoke

Actuator Size	A	B	C
314	49.8	24.5	23.7
154	47.8	14.8	21.8

Recommended Spare Parts

Ref No.	Description	Without Handjack Qty	With Handjack Qty	Actuator Size	
				314 Sq. In.	154 Sq. In.
2	O-ring, Piston & Caps	3	3	971886305-699-0000	326552000-699-0000
3	Cap Screw, Hex Head	4	4	971012005-110-0000	971012005-110-0000
22	O-ring, Bushing, O.D.	2	1	318724000-699-0000	318724000-699-0000
24	Bushing	2	1	010856025-485-0000	010856025-485-0000
25	O-ring, Bushing, I.D.	2	1	971886017-699-0000	971886017-699-0000
26	Stem Wiper	2	1	972001008-789-0000	972001008-789-0000
33-9	Hydraulic Fluid	A/R	A/R	972200004-779-0000	972200004-779-0000
35	O-ring, Hydraulic Cylinder	0	1	971886116-680-0000	971886068-699-0000
59	Guide Ring	2/1	2/1	355900116-779-0000 (uses 2)	355900115-779-0000 (uses 1)

Find the nearest local Channel Partner in your area:

valves.bakerhughes.com/contact-us

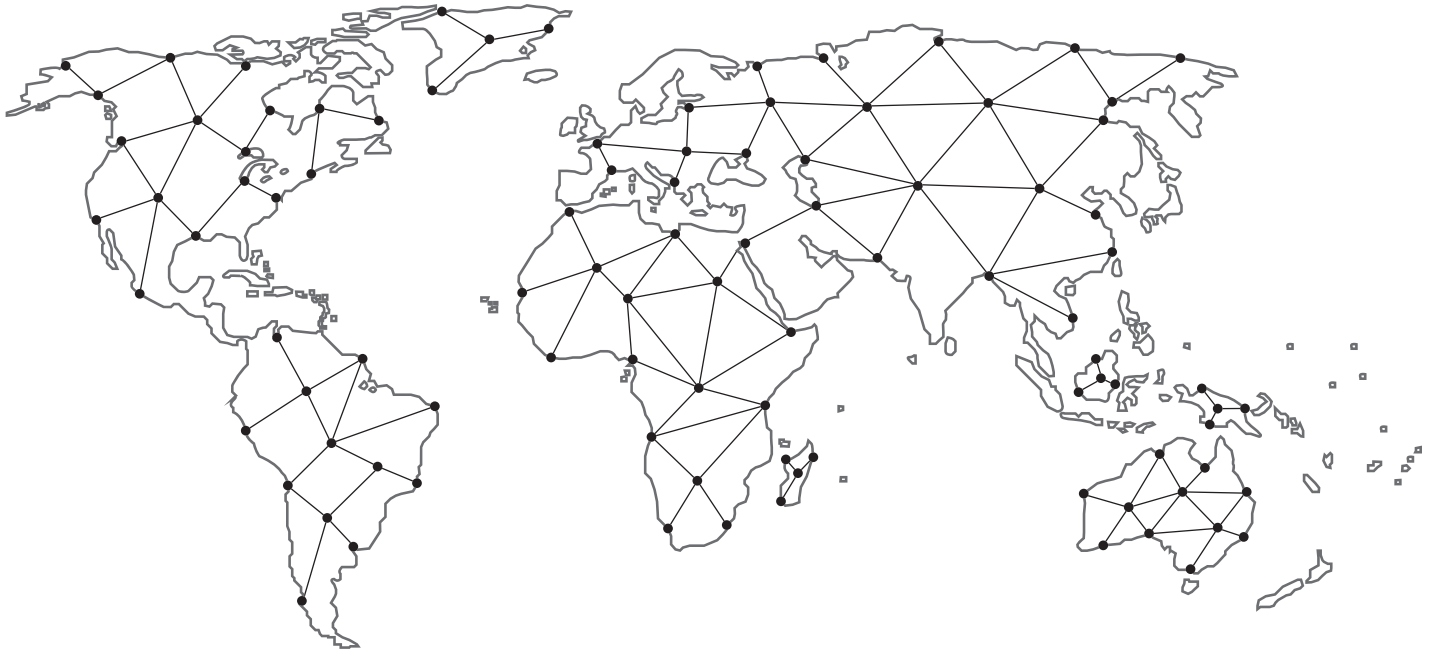

Tech Field Support & Warranty:

Phone: +1-866-827-5378

valvesupport@bakerhughes.com

valves.bakerhughes.com

Copyright 2021 Baker Hughes Company. All rights reserved. Baker Hughes provides this information on an "as is" basis for general information purposes. Baker Hughes does not make any representation as to the accuracy or completeness of the information and makes no warranties of any kind, specific, implied or oral, to the fullest extent permissible by law, including those of merchantability and fitness for a particular purpose or use. Baker Hughes hereby disclaims any and all liability for any direct, indirect, consequential or special damages, claims for lost profits, or third party claims arising from the use of the information, whether a claim is asserted in contract, tort, or otherwise. Baker Hughes reserves the right to make changes in specifications and features shown herein, or discontinue the product described at any time without notice or obligation. Contact your Baker Hughes representative for the most current information. The Baker Hughes logo and Maseonilan are trademarks of Baker Hughes Company. Other company names and product names used in this document are the registered trademarks or trademarks of their respective owners.

Baker Hughes 

bakerhughes.com